

描述 / Descriptions

SOT23-6 塑封封装锂电池保护 IC。 Battery Protection IC in a SOT23-6 Plastic Package.

特征 / Features

(1) 高精度电压检测电路/ Precision voltage detection circuit

过充检测电压 Overcharge detection voltage	4.3 V	精度 Accuracy	±50 mV
过充恢复电压 Overcharge release voltage	4.1 V	精度 Accuracy	±50 mV
过放检测电压 Overdischarge detection voltage	2.4 V	精度 Accuracy	±100 mV
过放恢复电压 Overdischarge release voltage	3.0 V	精度 Accuracy	±100 mV
过放电流检测电压 Discharge overcurrent detection voltage	0.14 V	精度 Accuracy	±30 mV
负载短路检测电压 Load short-circuiting detection voltage	1.2 V	精度 Accuracy	±300 mV

(2) 芯片内建检测延迟电路/ On-chip detection delay circuit

过充电检测延迟时间 Overcharge detection delay time	典型值 Typ	100ms
过放电检测延迟时间 Overdischarge detection delay time	典型值 Typ	100ms
过放电流检测延迟时间 Discharge overcurrent detection delay time	典型值 Typ	10ms
负载短路检测延迟时间 Load short-circuiting detection delay time	典型值 Typ	50μs

(3) 耐高压充电器保护最大额定电压 (VM 与CO 管脚额定电压为28V)

High voltage tolerance is used for charger connection pins, VM and CO pins are absolute maximum rating = 28V)

(4) 0V 可充,自恢复功能 0V battery charge function available , unavailable are selectable.

(5) 工作温度范围/ Operating Temperature Range -40 to +85°C

(6) 低自耗电流/ Low self current consumption

正常工作模式/ Operation mode	典型值/Typ 2.4μA	最大值/Max 6.0μA (25°C)
待机模式 / Standby Mode	休眠功能/ Green-mode	最大值/Max 0.1μA (25°C)
自恢复功能/ Self-recovery function		最大值/Max 3.0μA (25°C)

用途 / Applications

用于锂离子/锂聚合物可充电电池组。
For lithium ion / lithium polymer rechargeable battery pack.

内部等效电路 / Equivalent Circuit

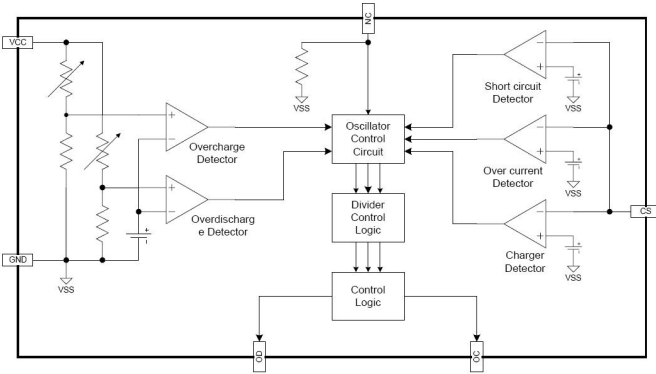

引脚排列 / Pinning

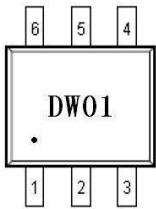

引脚名称 Pin Name	引脚序号 Pin Number	引脚功能 Pin Function
DO	1	放电控制输出端 Discharge control output terminal
V _m	2	充/放电电流检测输入端 Charge/discharge current detection input
CO	3	充电控制输出端 Charge control output terminal
NC	4	不接 Not connected
V _{DD}	5	电源输入端 Power input
V _{SS}	6	电源接地端 Power ground terminal

印章代码 / Marking

见印章说明。 See Marking Instructions.

极限参数 / Absolute Maximum Ratings(Ta=25°C)

参数 Parameter	符号 Symbol	数值 Rating	单位 Unit
Supply voltage	V _{DD}	V _{SS} -0.3 to V _{SS} +12	V
VM pin Input voltage	V _M	V _{DD} -28 to V _{DD} +0.3	V
OC output pin voltage	V _{CO}	V _{DD} -28 to V _{DD} +0.3	V
OD output pin voltage	V _{DO}	V _{DD} -0.3 to V _{DD} +0.3	V
Operating Temperature	T _{opr}	-40 to +85	°C
Storage Temperature	T _{stg}	-55 to +125	°C

电性能参数 / Electrical Characteristics(Ta=25°C)

参数 Parameter	符号 Symbol	测试条件 Test Conditions	最小值 Min	典型值 Typ	最大值 Max	单位 Unit
Operating voltage between VDD&VSS	V _{DD}		1.5		9	V
Operating voltage between CO&VM	C _O		1.5		28	V
Minimum operating voltage for 0V charging	V _{st}	V _{DD} -V _M V _{DD} -V _{SS} =0V			1.2	V
Discharging overcurrent release resistance	R _{short}	V _{DD} =3.6 V _M =1.0V	30	50	100	KΩ
CO pin N _{ch} ON voltage V _{COL}				0.4	0.5	V
CO pin N _{ch} ON voltage V _{COH}			V _{DD} -0.1	V _{DD} -0.02		V
CO pin N _{ch} ON voltage V _{DOL}				0.2	0.5	V
CO pin N _{ch} ON voltage V _{DOH}			V _{DD} -0.1	V _{DD} -0.02		V
Current consumption	I _{DD}	V _{DD} =3.5V V _M =0V	1.2	2.4	6.0	μA
Current consumption at stand-by(Green)	I _{st1}	V _{DD} =2.0V V _M =2.0V			0.1	μA
Overdischarge current consumption(Self-recovery)	I _{DOX}	V _{DD} =2.0V, V _M =2.0V		1.8	3.0	μA
Overcharge detection voltage	V _{det1}		4.25	4.3	4.35	V
Overcharge release voltage	V _{rel1}		4.05	4.1	4.15	V
Overcharge hysteresis voltage	V _{hys1}	V _{hys1} =V _{det1} -V _{rel1}		0.2		V
Overdischarge detection voltage	V _{det2}	V _M =0V	2.3	2.4	2.5	V

电性能参数 / Electrical Characteristics(Ta=25°C)

参数 Parameter	符号 Symbol	测试条件 Test Conditions	最小值 Min	典型值 Typ	最大值 Max	单位 Unit
Overdischarge release voltage	V_{rel2}		2.9	3.0	3.1	V
Overdischarge release voltage2	$V_{rel2'}$	$V_M=V_{chg}$	2.3	2.4	2.5	V
Discharging over current detection voltage	V_{det3}	$V_{DD}=3.6V$	0.11	0.14	0.17	V
Short detection voltage	V_{short}	$V_{DD}=3.6V$	0.9	1.2	1.5	V
Overcharge detection delay time	T_{Vdet1}	$V_{DD}=3.8V \rightarrow 4.5V$	50	100	200	ms
Overdischarge detection delay time	T_{Vdet2}	$V_{DD}=3.2V \rightarrow 2.2V$	50	100	200	ms
Discharging over current detection delay time	T_{Vdet3}	$V_{DD}=3.0V$ $V_M=0V \rightarrow 0.2V$	5	10	20	ms
Short detection delay time	T_{short}	$V_{DD}=3.5V$ $V_M=0V \rightarrow 1.0V$		50	100	μs
Charger detection voltage	V_{chg}	$V_{DD}=3.6V$	0.3	0.7	1.1	V

应用电路图/ Application Circuits:

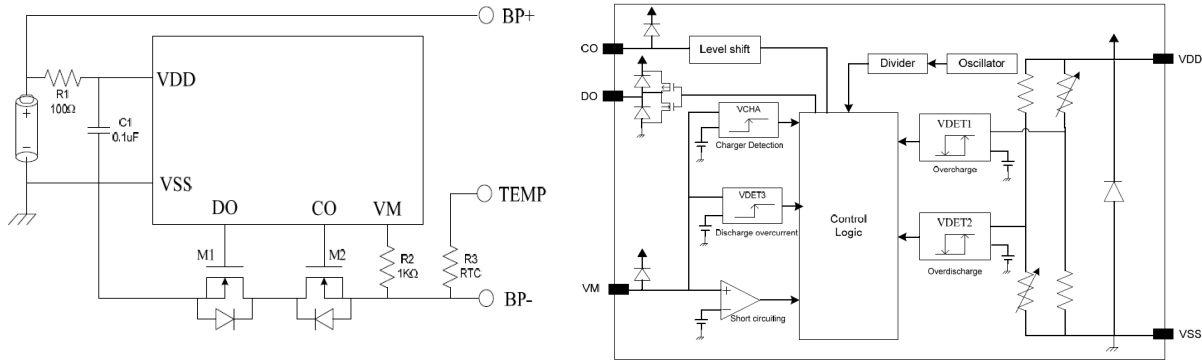

符号 Symbol	组件 Components	功能 Function	最小值 Min	典型值 Type	最大值 max	单位 Unit	附注 Notes
R1	电阻 Resistor	限流噪声滤波 Current limit Noise filtering		100	1K	Ω	*1
R2	电阻 Resistor	限流静电保护 Current limit ESD protection	300	1K	2K	Ω	*4
C1	电容 Capacitor	噪声滤波 Noise Filtering	0.022	0.1	1.0	μF	*3
M1	N 沟道 N-MOSFET	放电开关 Discharge switch					*2
M2	N 沟道 N-MOSFET	充电开关 Charging switch					*2

附注/Notes:

*1: R1 是单级的 RC 滤波器中更好的滤波效果的较高的电阻，如果 R1 的电阻 比推荐值更高，这将影响内部的检测电路和电压检测精度将超出规定范围。我们建议使用应用推荐的阻力。

R1 is a single-stage RC filter, the higher resistance of R1, the better the filtering effect. If the R1 resistance higher than the recommended value, it will affect the internal detection circuit and the voltage detection accuracy will out of specification. We suggest using the recommended resistance in application.

*2: CO 和虚拟机的绝对最大额定值为 28V，客户可以选择 20V 或 30V 双 N-MOS 管开关，用于不同的应用。

The absolute maximum rating of CO and VM is 28V, customer could choose 20V or 30V dual N-MOSFET switches for different application.

*3: 添加一个电容 C1 VDD 和 VSS 之间可以过滤传导和辐射噪声。

Add a C1 capacitor between VDD and VSS could filter conduction and radiation noise.

*4: R2 电阻可以有一个电流限制功能，限制充电电流浪涌。

R2 resistor could have a current limit function and limit charger current surge.

工作时序图/ Timing Chart

(1) 过充保护/过充恢复& 过放保护/过放恢复

Overcharge protection / overcharge recovery & Over-discharge protection / over-discharge recovery:

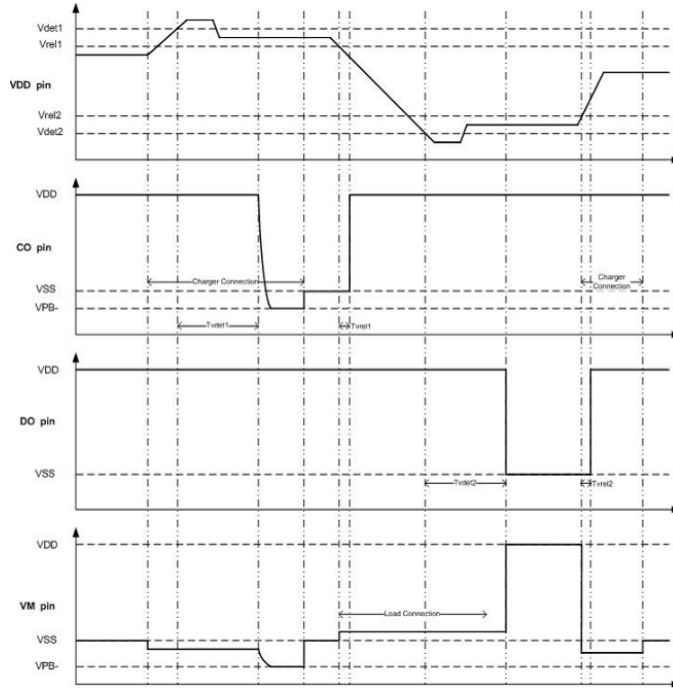

(2) 过流保护检测& 负载短路保护检测

Overcurrent detection & Load short-circuit protection detection

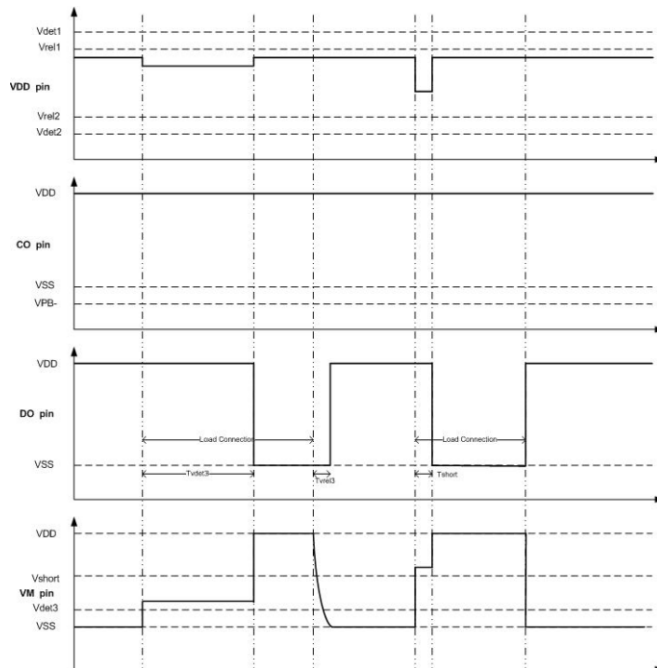

外形尺寸图 / Package Dimensions

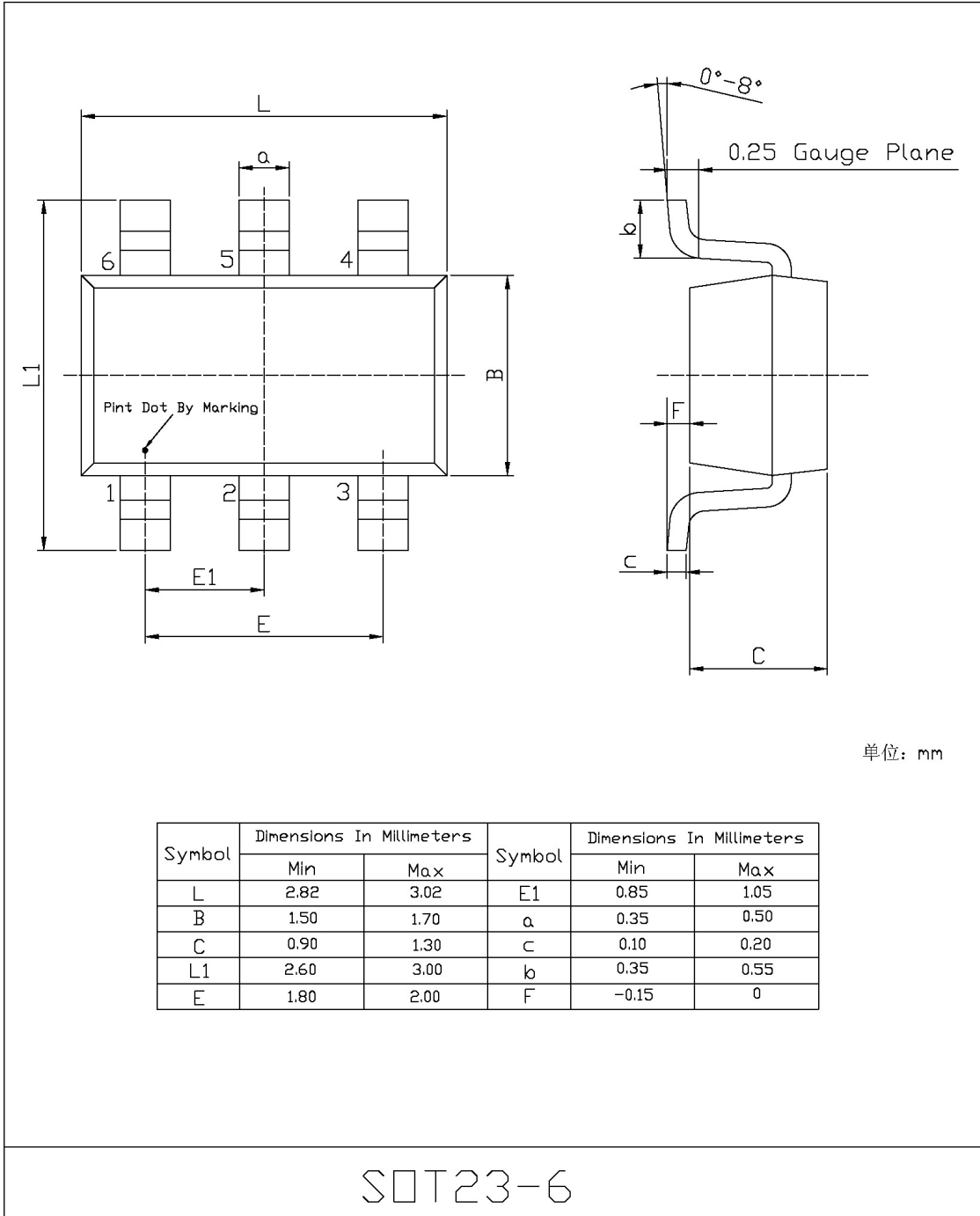

印章说明 / Marking Instructions

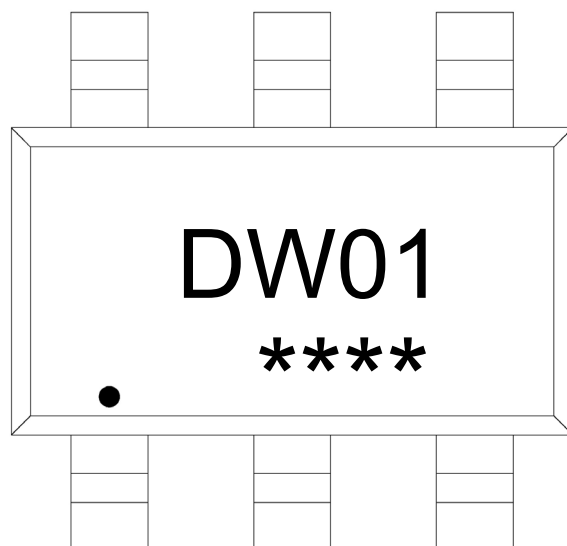

说明：

DW01： 为产品型号

****： 为生产批号代码，随生产批号变化。

Note:

DW01: Product Type.

****: Lot No. Code, code change with Lot No.

回流焊温度曲线图(无铅) / Temperature Profile for IR Reflow Soldering(Pb-Free)

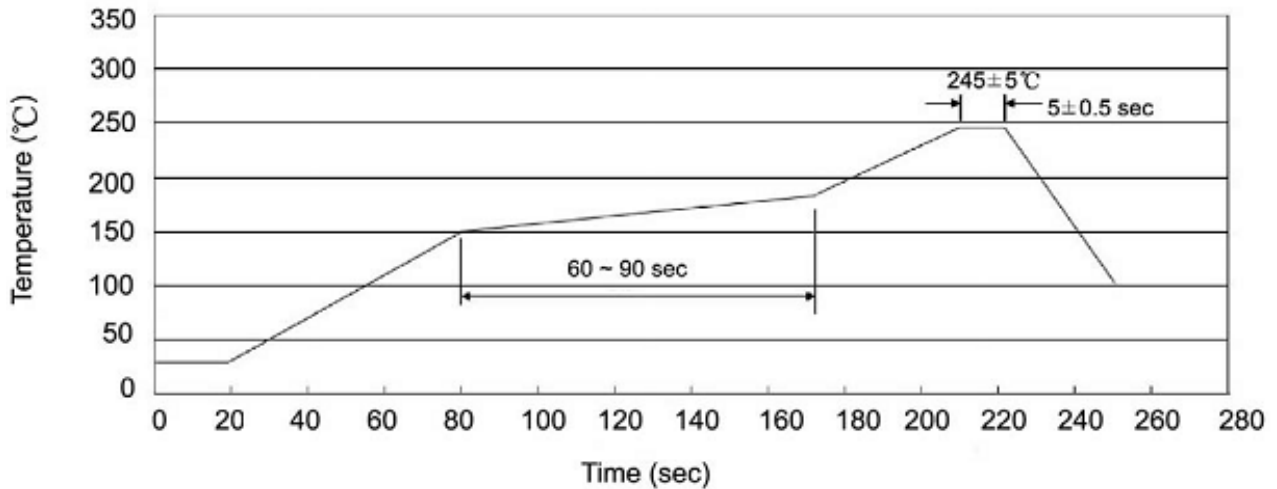

说明：

- 1、预热温度 150 ~ 180°C，时间 60 ~ 90sec；
- 2、峰值温度 245±5°C，时间持续为 5±0.5sec；
- 3、焊接制程冷却速度为 2 ~ 10°C/sec.

Note:

- 1.Preheating:150~180°C, Time:60~90sec.
- 2.Peak Temp.:245±5°C, Duration:5±0.5sec.
3. Cooling Speed: 2~10°C/sec.

耐焊接热试验条件 / Resistance to Soldering Heat Test Conditions

温度：260±5°C

时间：10±1 sec.

Temp.:260±5°C

Time:10±1 sec

包装规格 / Packaging SPEC.

卷盘包装 / REEL

Package Type 封装形式	Units 包装数量					Dimension 包装尺寸 (unit: mm ³)		
	Units/Reel 只/卷盘	Reels/Inner Box 卷盘/盒	Units/Inner Box 只/盒	Inner Boxes/Outer Box 盒/箱	Units/Outer Box 只/箱	Reel	Inner Box 盒	Outer Box 箱
SOT23-5/6	3,000	10	30,000	4	120,000	7" x8	210×205×205	445×230×435

使用说明 / Notices